

TIG TORCHES

WTT2

STANDARD RANGE

Simple and reliable, this range is adapted to the most common applications.



Standardised wear parts.



Handle, made with high temperature silicon rubber.



Easy pivoting handle (for EB handles).

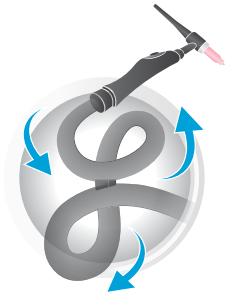

Extra-flexible high performance cable.



Handle

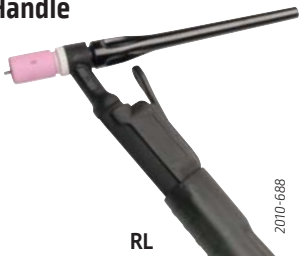

RL

2016-688



EB

2016-685

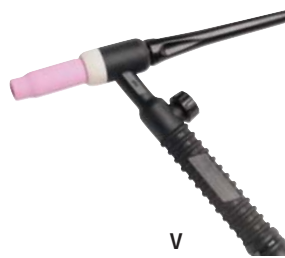

V

2016-686



EB-FLEX

2015-673

Air cooling

MODEL		WTT2 9		WTT2 17		WTT2 26			
Duty cycle at 40 °C		60%	80 A	100 A	130 A	130 A	180 A		
		35%	110 A	135 A	180 A				
Original equipment		back cap	Long						
		nozzle	Ø 10 mm				Ø 12 mm		
		electrode	Ø 1.6 mm		Ø 2.0 mm		Ø 2.4 mm		
Length		4 m	8 m	4 m	8 m	4 m	8 m		
Handle	RL	Connection	S	W000278878	W000278923	W000278883	W000278918	W000278888	W000278914
			C5B	W000278879	W000278922	W000278884	W000278917	W000278890	W000278913
	EB		S	W000278877	W000278929	W000278881	W000278920	W000278886	W000278916
			C5B	W000278875	-	W000278882	W000278919	W000278887	W000278915
	V		V (Conn. 9 mm)	W000278876	-	W000278880	-	-	-
			V (Conn. 13 mm)	-	-	W10529-17-4V	-	W000278885	-
	EB-FLEX		S / C5B	W000382781	-	W000382782	W000382783	W000382784	W000382785

Connections

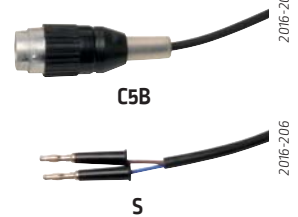

C5B

S

Connector:

Shaped cable output for a better robustness.



Air cooling



Water cooling

Water cooling

MODEL		WTT2 20 W		WTT2 18 W			
Duty cycle at 40 °C		100%	200 A	320 A			
		60%	250 A	350 A			
Original equipment		back cap	Long				
		nozzle	Ø 12 mm				
		electrode	Ø 2.4 mm				
Length		4 m	8 m	4 m	8 m		
Handle	RL	Connection	S	W000278893	W000278906	W000278897	W000278900
			C5B	W000278894	W000278905	W000278898	W000278899
	EB		S	W000278891	W000278911	W000278895	W000278902
			C5B	W000278892	W000278909	W000278896	W000278901
	EB-FLEX		S / C5B	W000382786	W000382787	W000382788	W000382789

TIG TORCHES

WTT2 TIG torches wear parts

		WTT2 9 / 9V WTT2 20W	WTT2 17 / 17V WTT2 26 / 26V WTT2 18W	
1-1	Back cap short	W000306398	W000306399	
1-2	Back cap medium	W000306400	-	
1-3	Back cap long	W000306402	W000306403	
2	Back cap O-ring	W000306404	W000306405	
4-2	Sealing ring	W000306396	W000306397	
4-1	Insulating ring	W000270780	W000306395	
3	Collet	∅ 1.0	W000306406	W000306411
		∅ 1.6	W000306407	W000306412
		∅ 2.0	W000306408	W000306413
		∅ 2.4	W000306409	W000306414
		∅ 3.2	W000306410	W000306415
		∅ 4.0	-	W000306416
5	Collet body	∅ 1.0	W000306376	W000306380
		∅ 1.6	W000306377	W000306381
		∅ 2.0	W000306378	W000270781
		∅ 2.4	W000306455	W000306382
		∅ 3.2	W000306379	W000306383
		∅ 4.0	-	W000306384
6-1	Nozzle	∅ 6.4	W000306417	W000306423
		∅ 8.0	W000306418	W000306424
		∅ 9.6	W000306419	W000306425
		∅ 11.2	W000306420	W000306426
		∅ 12.8	W000306421	W000306427
		∅ 16.0	W000306422	W000306428
		∅ 19.2	-	W000306461
6-2	Long nozzle	∅ 4.8	W000306456	-
		∅ 6.4	W000306457	W000306462
		∅ 8.0	W000306458	W000306463
		∅ 9.6	W000306459	W000306464
		∅ 11.2	-	W000306465
7	Gas Lens sealing ring	-	W000306466	
8	Gas Lens collet body	∅ 1.0	W000306385	W000306389
		∅ 1.6	W000306386	W000306390
		∅ 2.0	W000306460	-
		∅ 2.4	W000306387	W000306391
		∅ 3.2	W000306388	W000306392
		∅ 4.0	-	W000306393
9-1	Gas Lens nozzle	∅ 6.4	W000306429	W000306434
		∅ 8.0	-	W000306435
		∅ 9.6	W000306431	W000306436
		∅ 11.2	W000306432	W000306437
		∅ 12.8	W000306433	W000306438
		∅ 16.0	-	W000306439
9-2	Long Gas Lens nozzle	∅ 8.0	-	W000306467
		∅ 9.6	-	W000306468
		∅ 11.2	-	W000306469
		∅ 12.8	-	W000306470

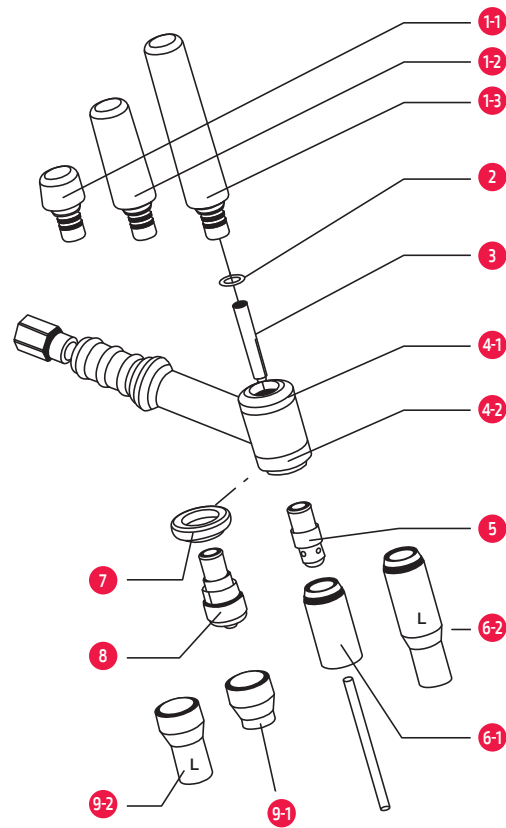

Wear parts box

For an easier maintenance of the WTT2 torches, two boxes are available.



Box for WTT2 9 / 9V / 20W

To order W000371535

Box for WTT2 17 / 26 / 18W

To order W000371536

Gas Lens

The gas diffuser concentrates the flux in a homogenous and focused way around the tungsten electrode, which allows to get the electrode out much more than the nozzle.

This permits to access to the difficult access welding joints.



TIG TORCHES

PROTIG NG S & III S

The range of PROTIG includes 4 air cooled, and 3 water cooled versions.

All torches are supplied ready to use, the standard fitting table gives more information.

Advantages:

- ◆ Wear parts and accessories are the same for the whole PROTIG range.
- ◆ The blade trigger may be oriented around the handle *[only for PROTIG III S]*.
- ◆ Robust metal trigger *[only for PROTIG III S]*.
- ◆ Neoprene sleeve with good maneuverability.
- ◆ 1 reference: the C5B connection of the torch is fitted as standard. It comes with banana plugs.



Air cooled

MODEL			PROTIG 10		PROTIG 20		PROTIG 30		PROTIG 40	
Duty cycle 35%			125 A		150 A		200 A		250 A	
Duty cycle 60%			80 A		100 A		130 A		200 A	
Fitted as standard	back cap		Long							
	nozzle		Ø 10 mm				Ø 12 mm			
	electrode		Ø 1.6 mm		Ø 2.0 mm		Ø 2.4 mm			
Length			5 m	8 m	5 m	8 m	5 m	8 m	5 m	8 m
PROTIG III S	Connection	C5B/S	W000382715-2	W000382716-2	W000382717-2	W000382718-2	W000382719-2	W000382720-2	W000382721-2	W000382722-2
PROTIG NG S			W000278394-2	W000278395-2	W000278396-2	W000278397-2	W000278398-2	W000278399-2	W000278400-2	W000278401-2

PROTIG III S

The round handle with a blade trigger (RL).

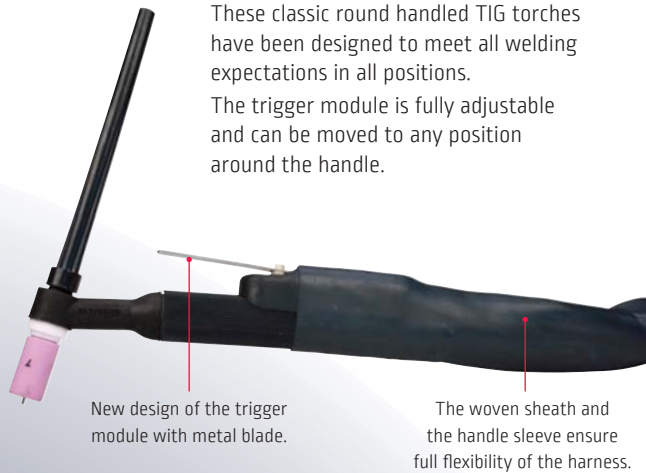

PROTIG NG S

The ergonomic handle with button (EB).



TIG TORCHES



Water cooled

MODEL		PROTIG 10W		PROTIG 35W		PROTIG 40W	
Duty cycle 100%		220 A		350 A		450 A	
Fitted as standard	back cap	long					
	nozzle	Ø 12 mm		Ø 15 mm		Ø 14 mm	
	electrode	Ø 2.4 mm		Ø 4.0 mm		Ø 4.8 mm	
Length		5 m	8 m	5 m	8 m	5 m	8 m
PROTIG III S	Connection	C5B/S	W000382723-2	W000382724-2	W000382725-2	W000382726-2	W000382727-2
PROTIG NG S			W000278402-2	W000278403-2	W000278404-2	W000278405-2	W000278406-2

⚠ Some machines require the use of the plug module p/n WP10529-5, see the section "Plug kits and button modules" at page 71.

Connectors, adapters

Connectors

The connectors to the machine are a new design, compact and fully protected delivering both strength and quality. All hoses are rubber with a woven sheath for heavy duty work.

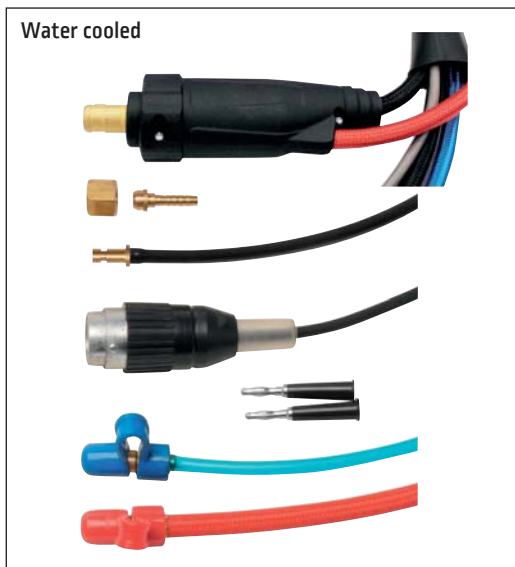

Adapters

For old torches with central gas to be connected to power sources with separate gas, use **W000306140**.



For torches with separate gas to be connected to power sources with central gas, use **W000306141**.

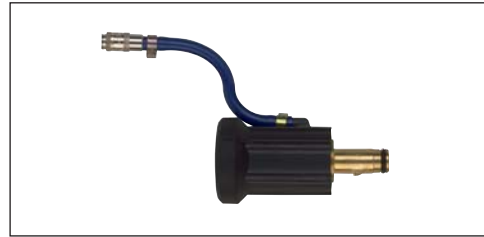

Dinse 9 to 13 mm - **W000306139**



Dinse 13 to 9 mm - **038055011**



TIG TORCHES

PROTIG NG S & III S

NEW

Wear parts

WELDLINE sets the standard for wear parts, ensuring maximum quality for both welding and gas protection.

Gas lens, for welding where access is difficult

PROTIG 40 W

A - insulating nut	W000306452
B - nozzle seals	W000167673
C - water distributor	W000306454

Nozzles 6 10 : choice of diameter

Welding current (A)	70	90	120	200	350
Diameter (mm)	6	8	10	12	15

The gas lens collet body 8 is supplied with a filter 9 and a sealing ring 7.
The ring 7 or the filter 9 are supplied on their own.

Wear parts box

A complete kit for all applications. The kit includes electrode collets, nozzles, back caps and collet body.

PROTIG 10 / 10W	W000306441
PROTIG 20	W000306442
PROTIG 30	W000306443
PROTIG 40 / 35W	W000306444
PROTIG 40W	W000306445



Modular system:

Standard delivery for EB all torches is a single button module. Other control module formats are available to order.



Other buttons

1 Horizontal potmeter	W000279370 [4,7 Kohm]	WP10529-3 [10 Kohm]
2 Vertical potmeter	W000279246 [4,7 Kohm]	WP10529-4 [10 Kohm]
3 3 buttons module	WP10529-2	
4 Blade	W000279245	

Adjustable heads

As an option, adjustable torch bodies are available, designed to make welding in limited access locations easier with a choice of 2 heads, small and large which are mounted on air cooled or water cooled bodies.



Choose one body and one head to get a complete torch.

· Air cooled body (10/20)	W000279381
· Water cooled body (10W)	W000279382
· Head PROTIG NG 10/10W	W000279383
· Head PROTIG NG 20	W000279384











△ Refer to the instruction manual to see the different connections for the modules. For potmeter adapt the wiring to the welding machine.

Wear parts are common for both RL or EB handles.

		PROTIG 10 / 10W	PROTIG 20	PROTIG 30	PROTIG 35W / 40	PROTIG 40W
1 - Back cap	short	W000306220	W000306223	W000306223	W000306225	W000306227
	medium	W000306221	-	-	-	-
	long	W000306222	W000306224	W000306224	W000306226	W000306228
2 - Back cap o-ring		W000306229	W000306230	W000306230	W000306231	W000306232
3 - Sealing ring		W000306210	W000306211	W000306211	W000306212	-
4 - Electrode collet	∅ 1.0	W000306236	W000306241	W000306246	W000306252	-
	∅ 1.6	W000306237	W000306242	W000306247	W000306253	-
	∅ 2.0	W000306238	W000306243	W000306248	W000306254	-
	∅ 2.4	W000306239	W000306244	W000306249	W000306255	W000306262
	∅ 2.5	W000306259	W000306260	W000306261	-	-
	∅ 3.2	W000306240	W000306245	W000306250	W000306256	W000306263
	∅ 4.0	-	-	W000306251	W000306257	W000306264
5 - Collet body all diameters		W000306205	W000306206	W000306207	W000306208	W000306200
5* - Collet body heavy duty		-	-	-	* W000306201	-
6 - Nozzle	∅ 6.4	W000306269	W000306273	W000306277	W000306277	-
	∅ 8	W000306270	W000306274	W000306278	W000306278	-
	∅ 9.6	W000306271	W000306275	W000306279	W000306279	-
	∅ 11	-	-	-	-	W000306282
	∅ 12.8	W000306272	W000306276	W000306280	W000306280	-
	∅ 14	-	-	-	-	W000306283
	∅ 15.7	-	-	W000306281	W000306281	-
6L - Long nozzle	∅ 4.8	W000306456	-	-	-	-
	∅ 6.4	W000306457	-	W000306462	W000306462	-
	∅ 8	W000306458	-	W000306463	W000306463	-
	∅ 9.6	W000306459	-	W000306464	W000306464	-
	∅ 11.2	-	-	W000306465	W000306465	-
	∅ 12.8	-	-	-	-	-
	∅ 14	-	-	-	-	-
7 - Gas lens sealing ring		W000306210	W000306216	W000306216	W000306217	-
8 - Gas lens collet body		W000306213	W000306214	W000306214	W000306215	-
9 - Gas lens filter		W000306218	W000306219	W000306219	W000306219	-
10 - Gas lens nozzle	∅ 8	W000306284	W000306287	W000306287	W000306287	-
	∅ 9.6	W000306285	W000306288	W000306288	W000306288	-
	∅ 11.2	W000306286	-	-	-	-
	∅ 12.8	-	W000306289	W000306289	W000306289	-
	∅ 15.7	-	W000306290	W000306290	W000306290	-
10L - Long gas lens nozzle	∅ 8	-	W000306467	W000306467	W000306467	-
	∅ 9.6	-	W000306468	W000306468	W000306468	-
	∅ 11.2	-	W000306469	W000306469	W000306469	-
	∅ 12.8	-	W000306470	W000306470	W000306470	-

* For the collet body « heavy duty », use the gas lens nozzles

Table of compatibility: plug kits & button modules

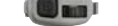
		Plug kits					
			WP10529-5	WP10529-6	WP10529-7	WP10529-8	WP10529-9
Button modules							
W000279241	1 button		ATTENTION WP10529-5 is compulsory in some cases: please read remark ⁽¹⁾	-----	-----	-----	-----
W000279245	1 button (French lever style)			-----	-----	-----	-----
WP10529-2	3 buttons ⁽²⁾		-----	-----	-----	-----	-----
W000279246	1 button 4.7 KOhm Vert Poti		-----	X (3)	X (4)	X (5)	-----
W000279370	1 button 4.7 KOhm Horiz Poti		-----	X (3)	X (4)	X (5)	-----
WP10529-3	1 button 10 KOhm Horiz Poti		-----	-----	-----	-----	-----
WP10529-4	1 button 10 KOhm Vert Poti		-----	-----	-----	-----	-----

(1) Plug kit WP10529-5 is compulsory to use a water cooled Protig torch with: Citotig II DC range, Prestotig II DC range, Prestotig/Citotig 240-310 AC/DC range, Prestotig/Citotig 350W; not needed with other machines. (2) Compatible with: Invertec 300TPX/400TPX, Aspect 300, Prestotig/Citotig 315/415/315AC/DC (no plug kit needed). (3) Compatible with: Prestotig 210 DC, Prestotig 310 DC, Prestotig 410 DC, Prestotig 240 ACDC, Prestotig 310 ACDC. (4) Compatible with: Prestotig 210 ACDC, Prestotig 250 ACDC, Prestotig 350 ACDC. (5) Compatible with: Saxotech 170/220, Saxotig 160 ACDC, Prestotig 180/220 Pro. (6) Compatible with: All Lincoln machines with pedal control, Prestotig/Citotig 315/415/315AC/DC.